

OUTLINE DRAWING

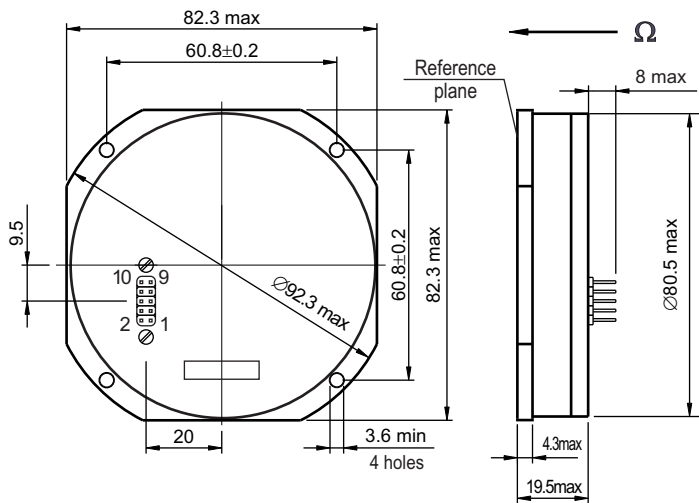

CONNECTION DIAGRAM

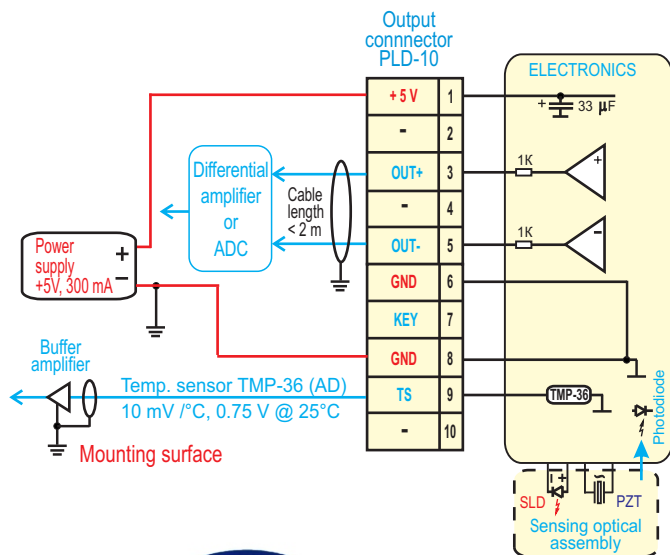

RECOMMENDATIONS AND PRECAUTIONS

1. Do not deform housing
2. Fragile components inside - no shocks, no drop
3. Treat as electrostatic sensitive unit
4. Is designed to be mounted inside water protected equipment
5. Increased humidity shortens essentially lifetime
6. Mounting surface must be grounded
7. Power must be off during connecting
8. Soldering to contacts - by low-temperature solder

MAIN PARAMETERS (typical values)

- ◆ Rate range 160 deg/s
- ◆ Scale Factor (SF) 8.4 mV/deg/s
- ◆ Frequency range 0... 1 kHz
- ◆ Angle random walk 0.03 deg /√h
- ◆ Bias stability, RMS 3 deg / h
- ◆ SF stability, RMS 0.1 %
- ◆ Readiness time 0.02 s

ENVIRONMENT

- ◆◆ OTR 1 -40°C ... +75°C
- ◆◆ OTR 2 (< 30 minutes) +75°C ... +125°C
- ◆ Exposure ( 2 hours max ) -55°C... +85°C
- ◆ Exposure ( 1 hour max ) +85°C... +125°C
- ◆ Vibration, RMS 12 g, 20Hz... 2000Hz
- ◆ Shock 500 g, 1 ms
- ◆ Acceleration 5 g

◆◆ RELIABILITY

- ◆◆ MTBF 60000 hours (20°C, predicted)
- ◆◆ Lifetime (predicted) 15 years
- ◆ Precision class - ④
- ◆◆ Estimated for low humidity
- ◆◆ OTR - operating temperature range

DESCRIPTION OF OUTPUT CONNECTOR PLD-10

Contact	Name	Comments
1	+ 5 V	Power input +5V ± 0.25V, 200mA max, ripple 10mV max within 0-1MHz
3	OUTPUT +	Analog output (+ 4.2 mV/°s), * 1V biased to GND
5	OUTPUT -	Analog output (- 4.2 mV/°s), * 1V biased to GND
6, 8	GND	Power return line, ground, "floating" contact to housing
7	KEY	Shortened pin
9	TS	Output of temperature sensor (TMP-36) 10mv per deg.C; 0.75V at 25 deg.C

\* - sensor's output is a difference between the voltages at 3 and 5 contacts

\*\* - 2, 4, 10 contacts are not used

PHYSICAL PARAMETERS

1. Ω - sensing axis, 90° ± 0.5° to the reference plane
2. Dissipation - 1 W
3. Weight - 110 gram ( 150 gram max )
4. Volume - 0.1 litre
5. Housing material - aluminum alloy
6. Housing protection - powder coating
7. Tolerances per ISO 2768-m
8. Ingress protection class - IP67